

Hunter's Quest

110 & 116 E. Carmel Drive
Carmel, Indiana 46032

2,480 SF AVAILABLE



- ▶ 1,240 SF fully built-out space for Retail or Office Lease
- ▶ 1,240 SF "white-box" space for Retail or Office Lease
- ▶ 13,200 SF Retail/Office Center located on Carmel Drive just east of Rangeline Road
- ▶ Located in Carmel, Indiana - ranked #1 "Best Places to Live in America" by Niche.com
- ▶ Additional signage available on illuminated ground sign
- ▶ High Traffic Exposure - Over 46,000 Vehicles Per Day



MARKET DEMOGRAPHICS

	Estimated Population	Avg HH Income	Daytime Population
1-Mile Radius	8,400	\$80,000	12,000
3-Mile Radius	66,000	\$103,000	68,000
5-Mile Radius	118,000	\$104,000	116,000

For more information, contact:

Brian Fineberg

Direct: (317) 844-3993

Mobile: (317) 727-4059

brian@fineberggroup.com



FINEBERG PROPERTY SERVICES

Commercial Real Estate Leasing
1 E. Carmel Drive, Suite 200
Carmel, IN 46032

Hunter's Quest

110 & 116 E. Carmel Drive
Carmel, Indiana 46032

2,480 SF AVAILABLE

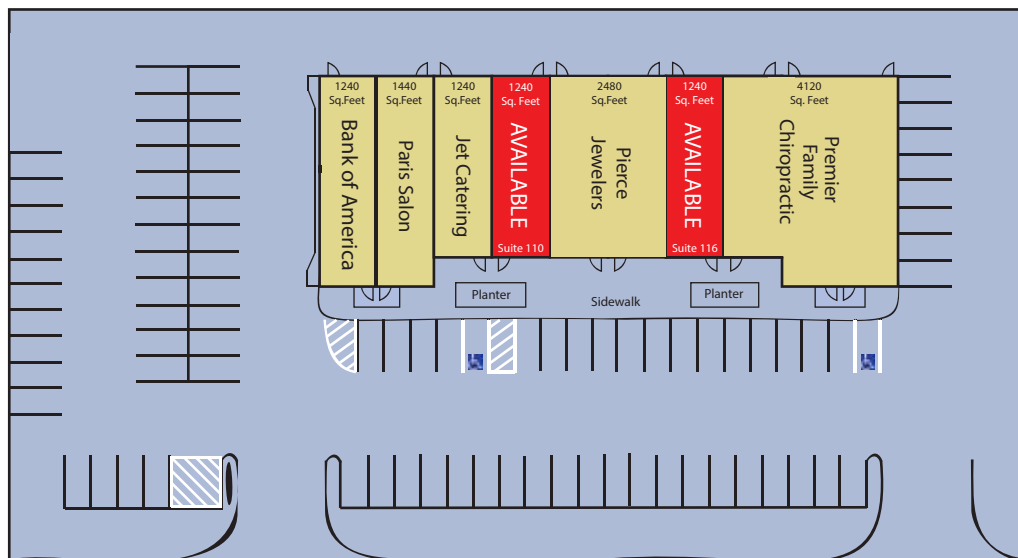

For more information, contact:

Brian Fineberg
Direct: (317) 844-3993
Mobile: (317) 727-4059
brian@fineberggroup.com



FINEBERG PROPERTY SERVICES
Commercial Real Estate Leasing
1 E. Carmel Drive, Suite 200
Carmel, IN 46032

Hunter's Quest

110 & 116 E. Carmel Drive
Carmel, Indiana 46032

2,480 SF AVAILABLE

116 E. Carmel Drive

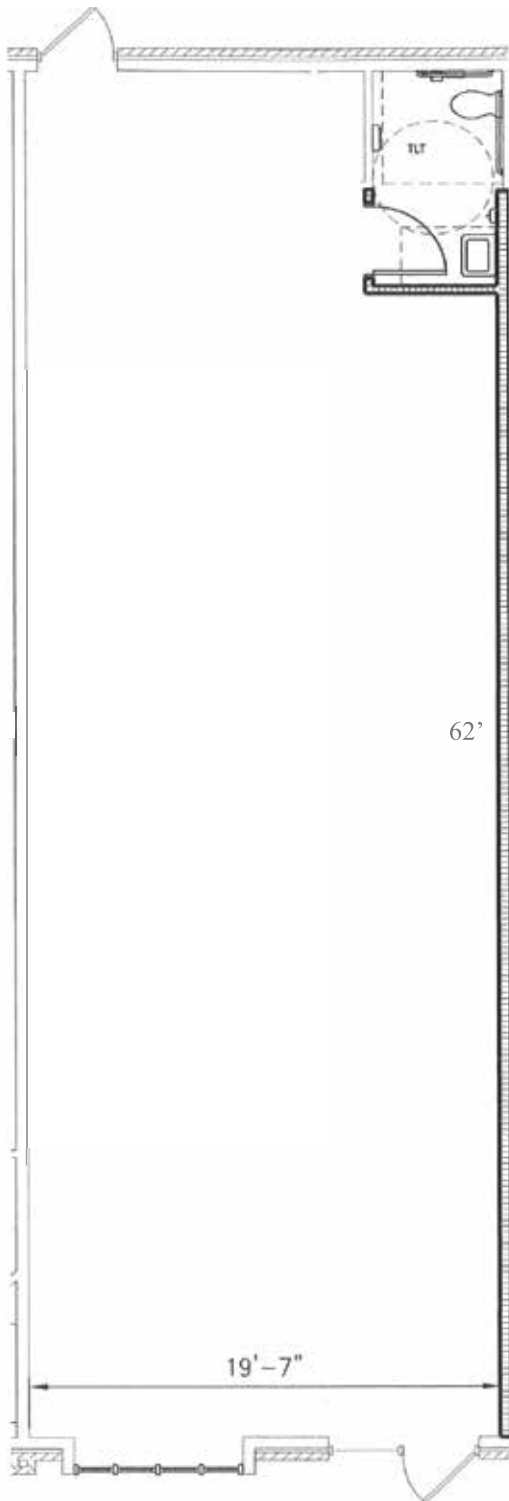

110 E. Carmel Drive

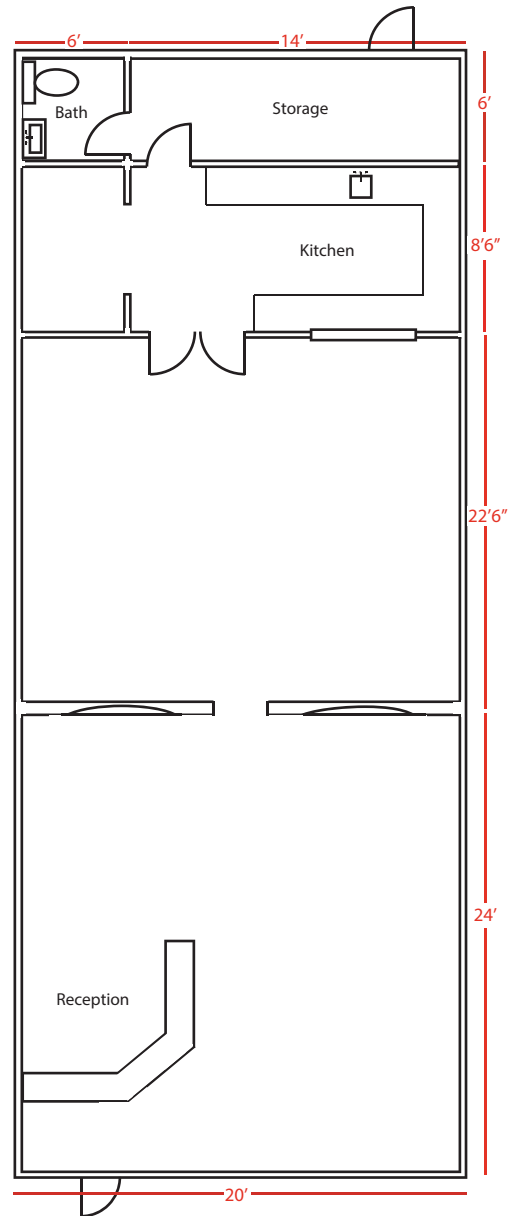

For more information, contact:

Brian Fineberg
Direct: (317) 844-3993
Mobile: (317) 727-4059
brian@fineberggroup.com



FINEBERG PROPERTY SERVICES
Commercial Real Estate Leasing
1 E. Carmel Drive, Suite 200
Carmel, IN 46032

Hunter's Quest

110 & 116 E. Carmel Drive
Carmel, Indiana 46032

2,480 SF AVAILABLE

110 E. Carmel Drive
Interior Photos



For more information, contact:

Brian Fineberg

Direct: (317) 844-3993

Mobile: (317) 727-4059

brian@fineberggroup.com



FINEBERG PROPERTY SERVICE
Commercial Real Estate Leasing
1 E. Carmel Drive, Suite 200
Carmel, IN 46032